



Accurate Kinetic Energy

No.11-3 Jianguo Rd., Tanzi Dist., 42760 Taiwan

All dimensions are millimeters.

CAD: TCR

Review: EG

Appr: JL

Page: 1/4 Date: April 16,2024

Specification Title:

Clock Oscillator Automotive Grade
LVDS - Complimentary Output
5.0 x 3.2 millimeter Surface Mount
General Product Specification

AEC-Q200 Qualified
IATF 16949 Certified

Part Number:

S5A Auto LVDS Series

Electrical Specifications:

Table with 6 columns and 20 rows detailing electrical specifications such as Frequency Range, Stability, Aging, Temperature Ranges, Supply Voltage, Input/Output Current, and Timing parameters.

Temperature stability is Inclusive of all conditions:

Calibration Tolerance at +25°C, frequency stability over the operating temperature range, supply voltage change, output load change, shock, vibration, and 1st year aging at +25°C.

Table with 4 columns: RoHS Compliant, Pb - Lead Free, AEC-Q200 Qualified, IATF 16949 Certified, Ltr, Revisions, Date, Appr.

Mechanical Outline and Solder Pad Layout:

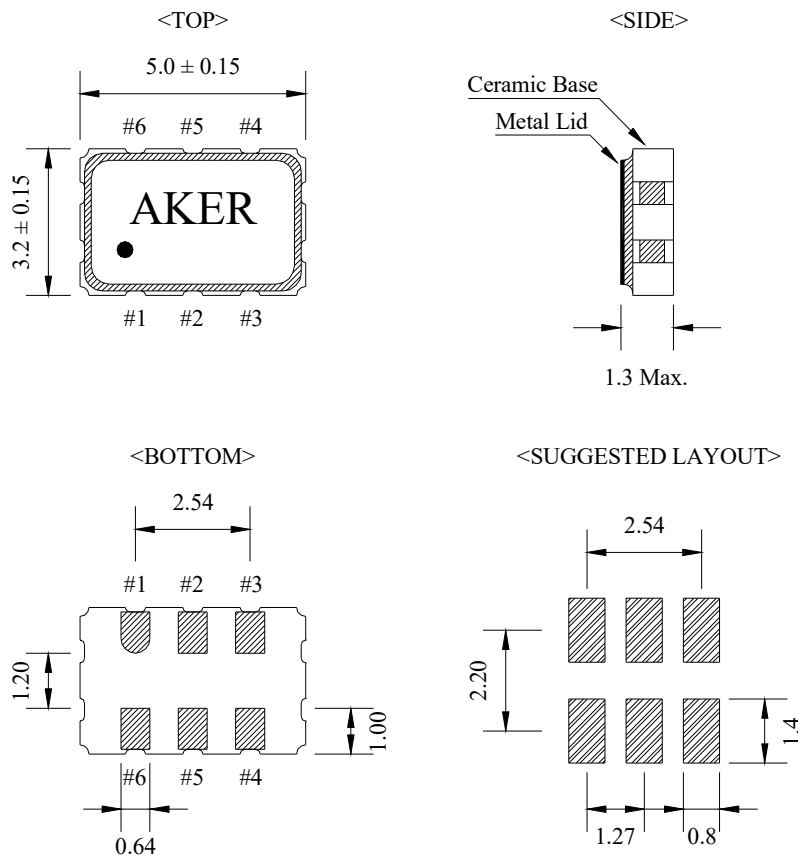

Pin Connection	
PIN No.	Connection
#1	Enable/Disable
#2	NC
#3	GND
#4	Output - Q
#5	Output - QN
#6	VDD

Enable/Disable Function	
PIN #1	PIN #4 & #5
HIGH or OPEN	Operating
LOW	High Impedance

Package is Seam Sealed Ceramic-Metal.

Terminator Pads are Ni/Au.

Dimensions are millimeters.

Carrier Tape Dimensions:

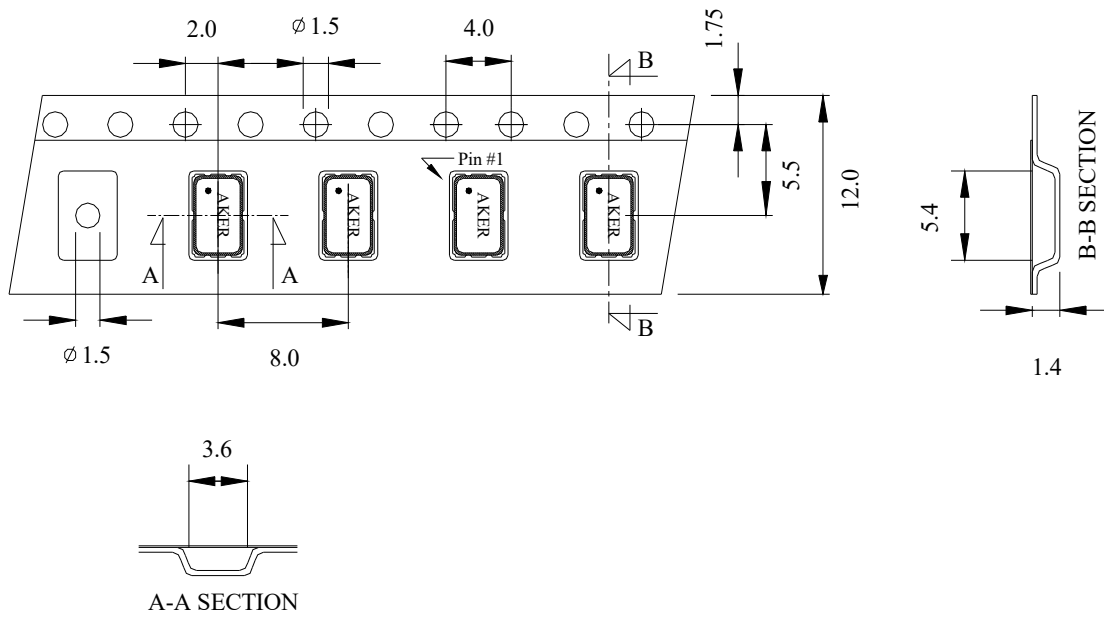

Dimensions are millimeters.

Solder Reflow Characteristics:

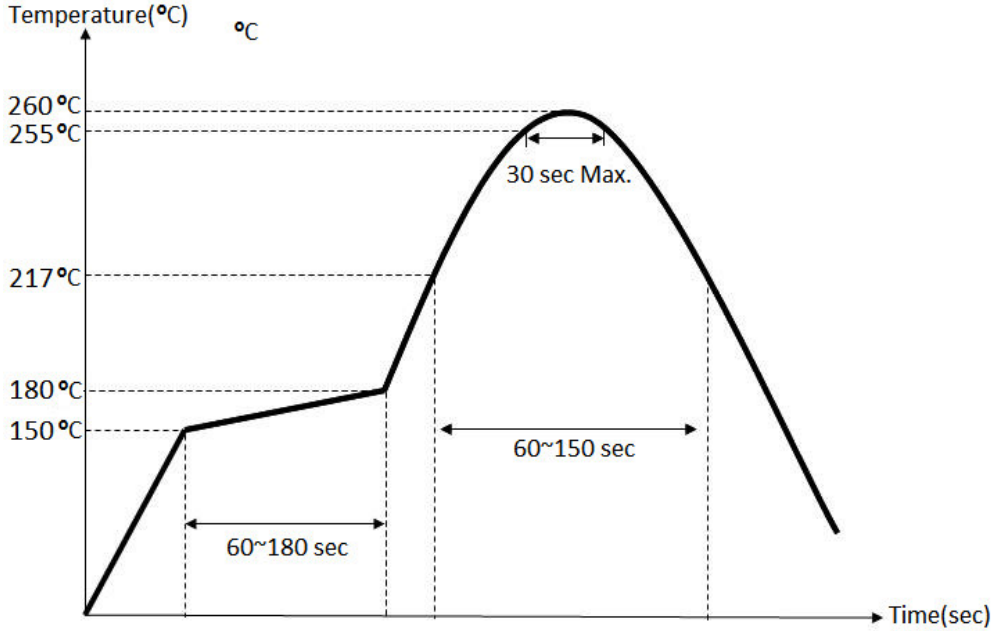

How to build a Part Number:

Series	S	Parameter
Package	5A	5.0 x 3.2 mm - 6 Pad
Supply Voltage	33	+3.3 VDD ± 5%
	25	+2.5 VDD ± 5%
	18	+1.8 VDD ± 5%
	M	+2.375 ~ +3.63 VDD
Temperature Stability	10	±100 ppm
	05	±50 ppm
	025	±25 ppm
Frequency	13.500~160.000	MHz
Output Load	L	LVDS
AECQ-200	A	Automotive
Temperature Range	See Notes	-20 ~ +70 °C
	X	-40 ~ +85 °C
	X1	-40 ~ +125 °C
	X2	-40 ~ +105 °C
Packaging	M	250pcs Reel
	R	1000pcs Reel

Part Number Example:

S5A3305-156.250-L-A-X-R

S5A: 5.0 x 3.2 mm SMD Package - 6 Pad

33: +3.3±5% VDD Supply Voltage

05: ±50 ppm Temperature Stability

156.250 MHz Nominal Frequency

L: LVDS Output

A: Automotive Grade

X: -40 ~ + 85°C Temperature Range

R: Tape and Reel Packaging - 1000pcs Reel

Notes:

- 1- Standard Duty Cycle and Temperature Range do not need to be included in Part Number description.
- 2- Product is shipped in Tape and Reel configuration.
- 3- Quantities less than 250pcs are shipped in tape only.
- 4- Specification subject to change without notice.